



US010497907B1

(12) **United States Patent**
Matsui et al.

(10) **Patent No.:** **US 10,497,907 B1**
(45) **Date of Patent:** **Dec. 3, 2019**

(54) **METHOD FOR MANUFACTURING DISPLAY DEVICE BY UV-CURING ORGANIC LAYER OF SEALING FILM**

(58) **Field of Classification Search**
CPC .. H01L 51/5253; H01L 51/5256; H01L 51/56
See application file for complete search history.

(71) Applicant: **Sharp Kabushiki Kaisha**, Sakai, Osaka (JP)

(56) **References Cited**

(72) Inventors: **Akihiro Matsui**, Sakai (JP); **Junpei Takahashi**, Sakai (JP); **Tohru Senoo**, Sakai (JP); **Takeshi Hirase**, Sakai (JP); **Tohru Sonoda**, Sakai (JP); **Takashi Ochi**, Sakai (JP); **Hisao Ochi**, Sakai (JP)

U.S. PATENT DOCUMENTS

9,843,013 B2* 12/2017 Sonoda H01L 51/524
2007/0176173 A1* 8/2007 Ramakrishnan H01L 51/5234
257/40

(Continued)

FOREIGN PATENT DOCUMENTS

JP 58-61275 A 4/1983
JP 2007-005189 A 1/2007

(Continued)

OTHER PUBLICATIONS

Official Communication issued in International Patent Application No. PCT/JP2017/034817, dated Dec. 12, 2017.

Primary Examiner — Michael Jung

(74) *Attorney, Agent, or Firm* — Keating & Bennett, LLP

(21) Appl. No.: **16/466,682**

(22) PCT Filed: **Sep. 26, 2017**

(86) PCT No.: **PCT/JP2017/034817**

§ 371 (c)(1),
(2) Date: **Jun. 5, 2019**

(87) PCT Pub. No.: **WO2019/064357**

PCT Pub. Date: **Apr. 4, 2019**

(51) **Int. Cl.**
H01L 51/56 (2006.01)
H01L 51/52 (2006.01)

(Continued)

(52) **U.S. Cl.**
CPC **H01L 51/56** (2013.01); **H01L 27/3244** (2013.01); **H01L 51/0097** (2013.01);

(Continued)

(57) **ABSTRACT**

Provided is a method for manufacturing an organic EL display device, including forming a sealing film to cover an organic EL element. The forming a sealing film includes forming a first inorganic layer to cover the organic EL element, forming a partition on the first inorganic layer, forming an organic layer on the first inorganic layer by applying an organic material inward from the partition on a surface of the first inorganic layer, removing the partition, and forming a second inorganic layer on the first inorganic layer to cover the organic layer.

5 Claims, 7 Drawing Sheets

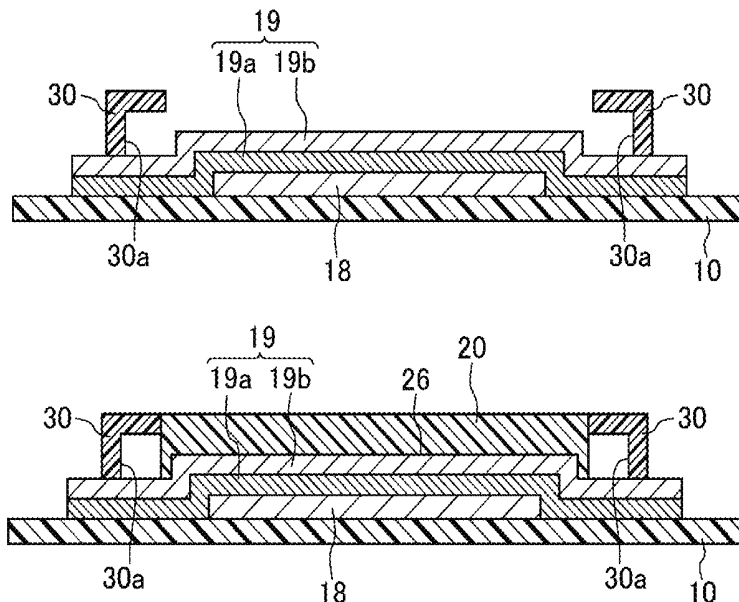

- (51) **Int. Cl.**
H01L 27/32 (2006.01)
H01L 51/00 (2006.01)
B05D 1/00 (2006.01)

- (52) **U.S. Cl.**
CPC *H01L 51/5253* (2013.01); *H01L 51/5256*
(2013.01); *B05D 1/60* (2013.01); *H01L*
2251/5338 (2013.01)

(56) **References Cited**

U.S. PATENT DOCUMENTS

2011/0140164	A1	6/2011	Seo et al.	
2016/0072099	A1*	3/2016	Okamoto	<i>H01L 51/5253</i> 257/40
2016/0155945	A1	6/2016	Lin et al.	
2017/0077463	A1*	3/2017	Chen	<i>H01L 51/0011</i>
2017/0244063	A1	8/2017	Furuie	

FOREIGN PATENT DOCUMENTS

JP	2011-124228	A	6/2011
JP	2013-073820	A	4/2013
JP	2015-201291	A	11/2015
JP	2017-147165	A	8/2017

* cited by examiner

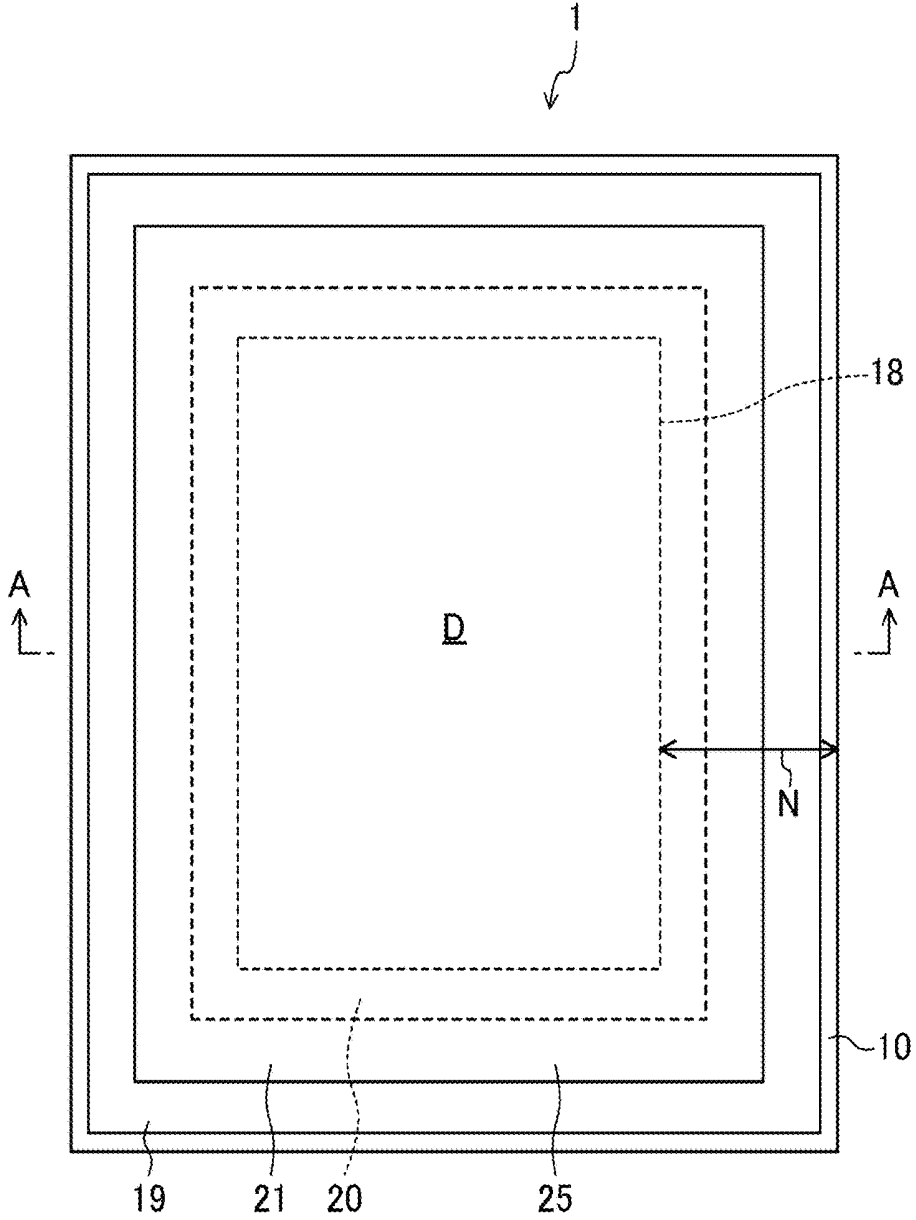

FIG. 1

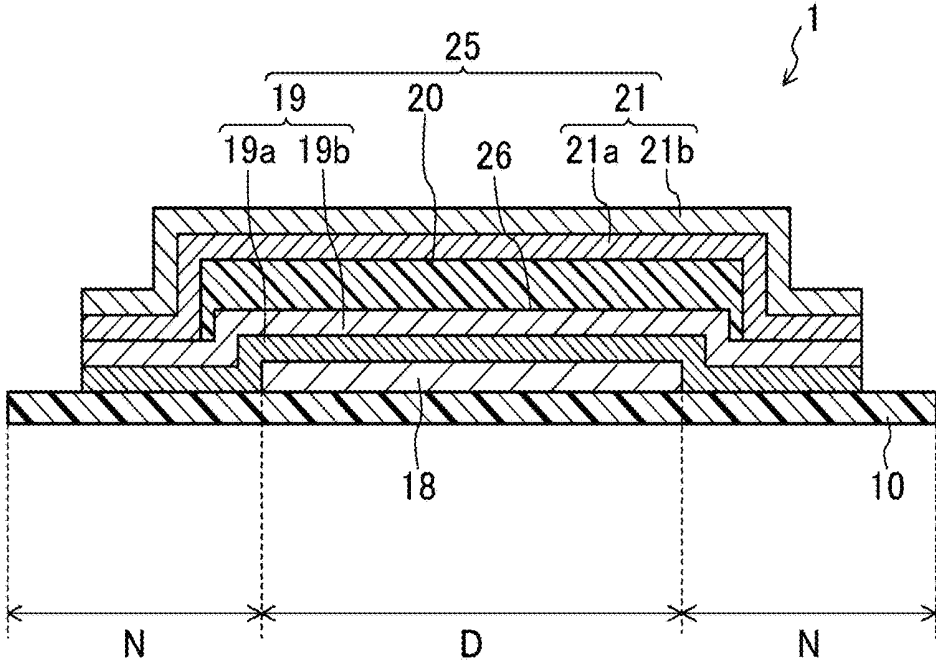

FIG. 2

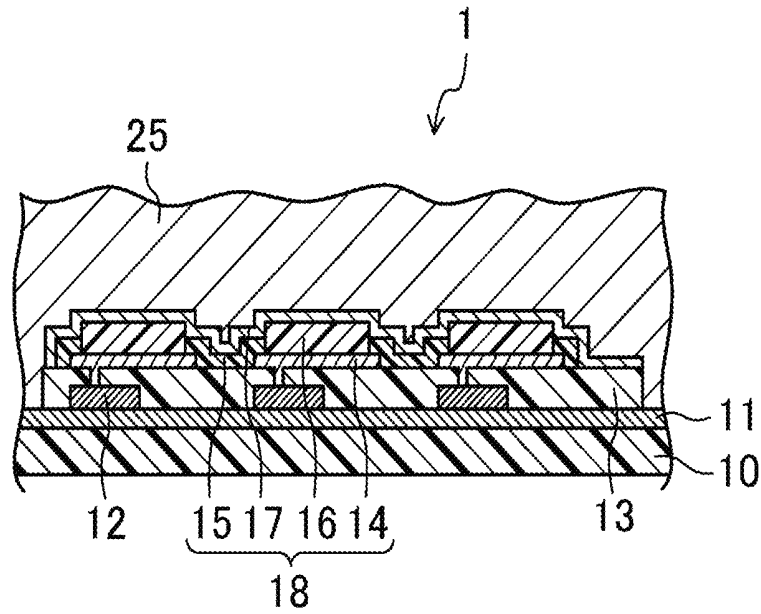

FIG. 3

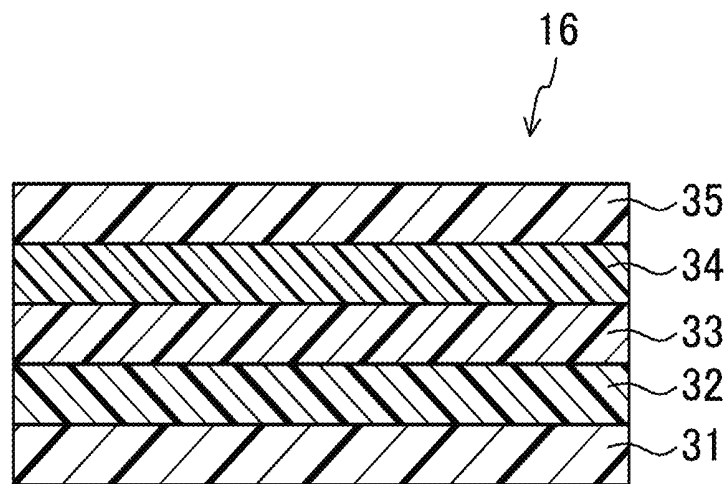

FIG. 4

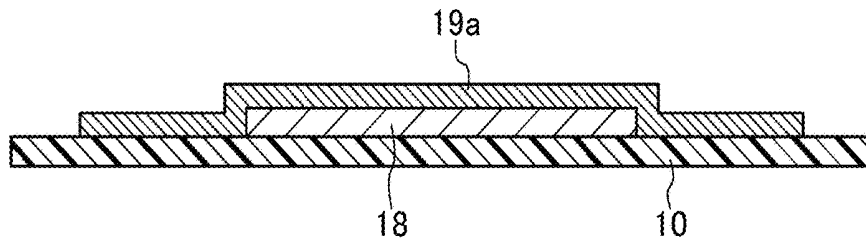

FIG. 5

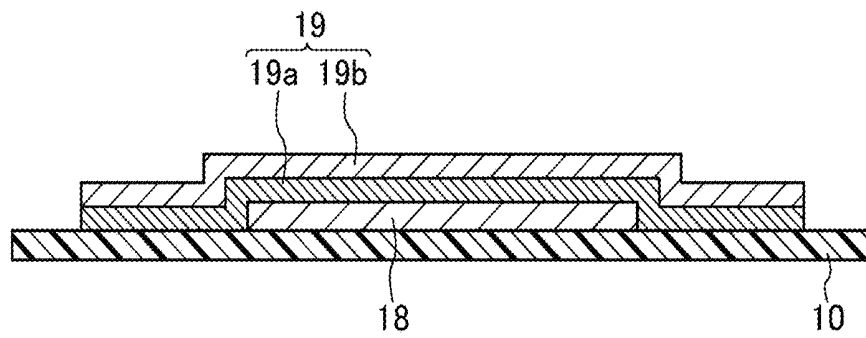

FIG. 6

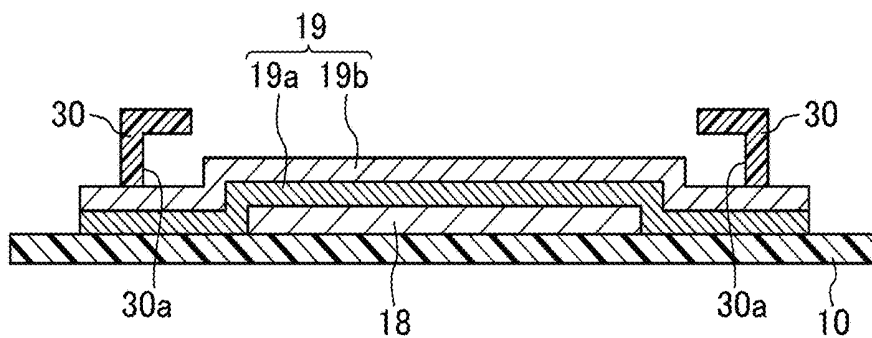

FIG. 7

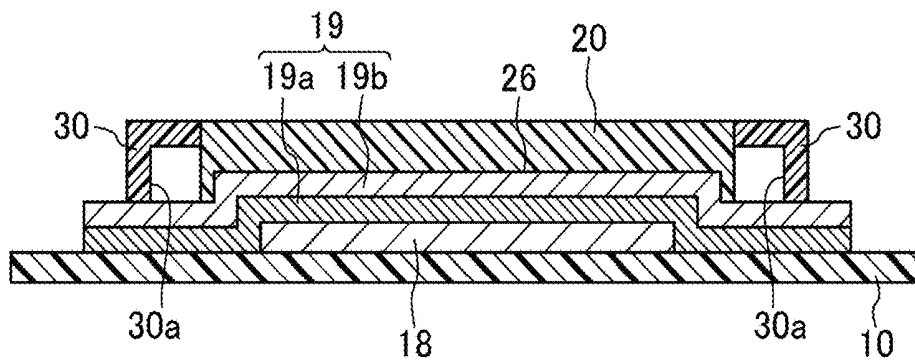

FIG. 8

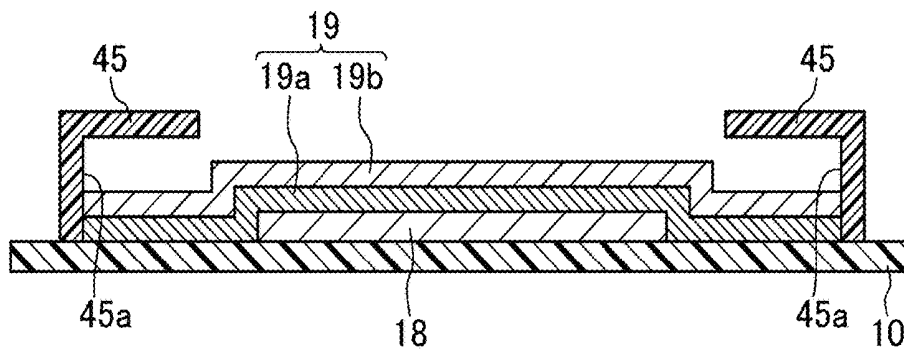

FIG. 9

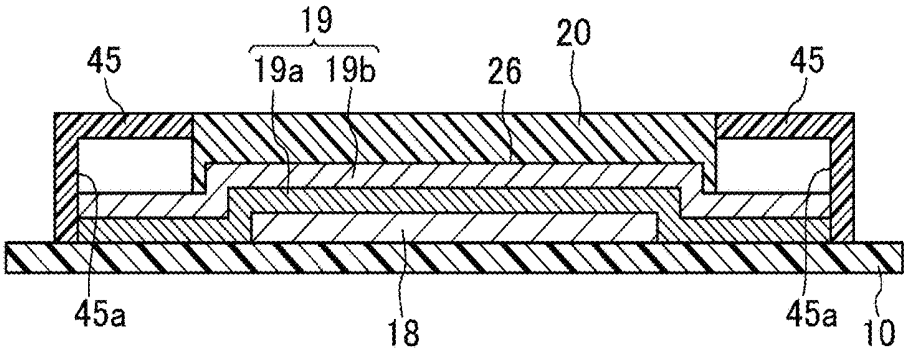

FIG. 10

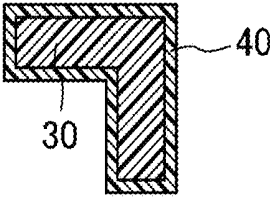

FIG. 11

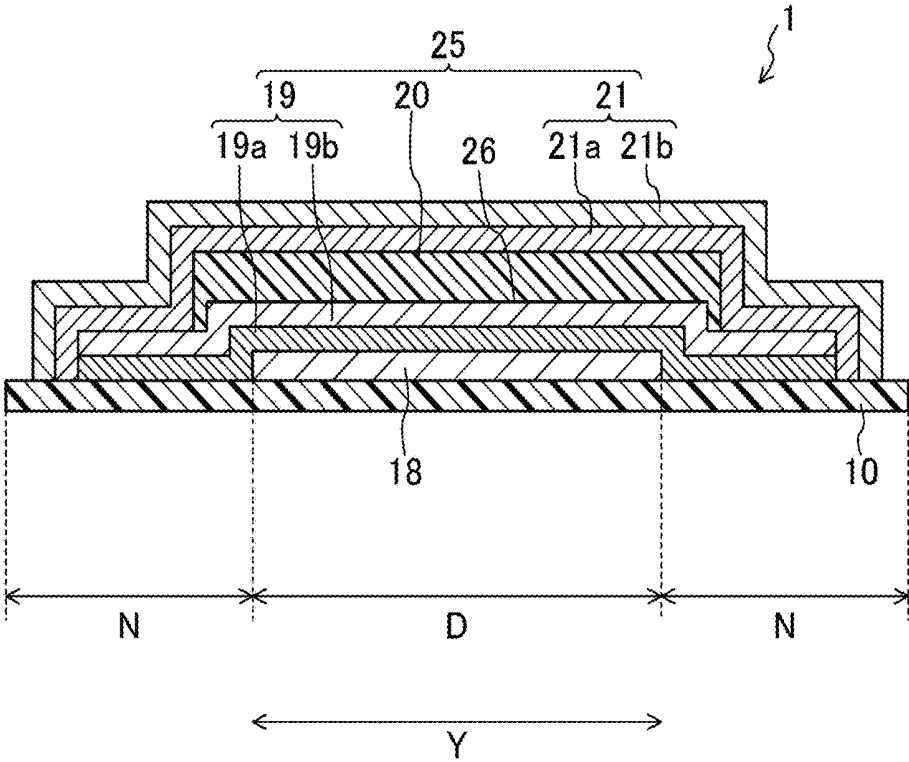

FIG. 12

METHOD FOR MANUFACTURING DISPLAY DEVICE BY UV-CURING ORGANIC LAYER OF SEALING FILM

TECHNICAL FIELD

The disclosure relates to a method for manufacturing a display device.

BACKGROUND ART

In recent years, organic EL display devices, which use organic electroluminescence (EL) elements and are of the self-luminous type, have attracted attention as a display device that can replace the liquid crystal display device. For the organic EL display device, a seal structure is proposed to inhibit degradation of the organic EL element due to penetration of, for example, moisture and oxygen. The seal structure includes a sealing film covering the organic EL element, and the sealing film includes a stack of an inorganic film and an organic film.

For example, disclosed is an organic EL display device including a sealing member including an organic layer and an inorganic layer. The organic layer covers an organic EL element and the inorganic layer is formed on the organic layer (e.g., see Patent Literature 1).

CITATION LIST

Patent Literature

PTL 1: JP 2013-73820A

SUMMARY

Technical Problem

However, the organic EL display device disclosed in PTL 1 has a problem in that it is necessary to provide, in a peripheral portion of a light emitting region, a dam wall (bank) that restricts spreading of an organic material ejected in a case that the organic material is ejected by using an ink-jet method to form an organic layer; thus, frame narrowing of the organic EL display device is difficult.

The disclosure has been accomplished in view of the above, and an object of the disclosure is to provide a method for manufacturing a display device, the method ensuring a sealing property of a seal film and causing frame narrowing to be provided.

Solution to Problem

In order to achieve the above object, a method for manufacturing a display device according to the disclosure includes forming a light emitting element on a base substrate, and forming a sealing film to cover the light emitting element. The forming a sealing film includes forming a first inorganic layer to cover the light emitting element, forming a partition on the first inorganic layer, forming an organic layer on the first inorganic layer by applying an organic material inward from the partition on a surface of the first inorganic layer, removing the partition, and forming a second inorganic layer on the first inorganic layer to cover the organic layer.

Advantageous Effects of Disclosure

The dam wall for restricting spreading of an organic material is unnecessary. Thus, there is no need to provide the

dam wall in the frame portion. As a result, the frame narrowing of the display device can be provided.

BRIEF DESCRIPTION OF DRAWINGS

FIG. 1 is a plan view of an organic EL display device according to a first embodiment of the disclosure, schematically illustrating a configuration of the device.

FIG. 2 is a cross-sectional view of the organic EL display device taken along line A-A of FIG. 1, schematically illustrating the configuration of the device.

FIG. 3 is a cross-sectional view of the organic EL display device according to the first embodiment of the disclosure, illustrating an internal structure of the device.

FIG. 4 is a cross-sectional view of an organic EL layer included in the organic EL display device according to the first embodiment of the disclosure.

FIG. 5 is a cross-sectional view illustrating a method for manufacturing the organic EL display device according to the first embodiment of the disclosure.

FIG. 6 is a cross-sectional view illustrating the method for manufacturing the organic EL display device according to the first embodiment of the disclosure.

FIG. 7 is a cross-sectional view illustrating the method for manufacturing the organic EL display device according to the first embodiment of the disclosure.

FIG. 8 is a cross-sectional view illustrating the method for manufacturing the organic EL display device according to the first embodiment of the disclosure.

FIG. 9 is a cross-sectional view illustrating a terminal section of an organic EL display device according to a second embodiment of the disclosure.

FIG. 10 is a cross-sectional view of the organic EL display device according to the second embodiment of the disclosure.

FIG. 11 is a cross-sectional view of a modified example of an organic EL display device according to the disclosure.

FIG. 12 is a cross-sectional view of a modified example of an organic EL display device according to the disclosure.

DESCRIPTION OF EMBODIMENTS

Embodiments of the disclosure will be described below in detail with reference to the drawings. The disclosure is not limited to the embodiments described below.

First Embodiment

FIG. 1 is a plan view of an organic EL display device according to the present embodiment, schematically illustrating a configuration of the device. FIG. 2 is a cross-sectional view of the organic EL display device taken along line A-A of FIG. 1, schematically illustrating the configuration of the device. FIG. 3 is a cross-sectional view of the organic EL display device, illustrating an internal structure of the device. FIG. 4 is a cross-sectional view of an organic EL layer included in the organic EL display device.

As illustrated in FIGS. 1 and 2, the organic EL display device 1 includes a base substrate 10, an organic EL element 18, and a sealing film 25. The base substrate 10 is provided as a base substrate and transparent. The organic EL element 18 is disposed on (indirectly on) the base substrate 10. The sealing film 25 is disposed to cover the organic EL element 18.

As illustrated in FIG. 1, in the organic EL display device 1, the organic EL element 18 is disposed in a rectangular shape in a plan view. Thus, a display region D is defined in

a rectangular shape, for displaying images. In the display region D, a plurality of pixels are arranged in a matrix form. Each of the pixels includes a subpixel for display of red gradation, a subpixel for display of green gradation, and a subpixel for display of blue gradation. These subpixels are disposed adjacent to one another.

As illustrated in FIG. 1, the organic EL display device 1 includes a frame region (non-display region) N. The frame region N is defined around the display region D and has a frame shape. As illustrated in FIG. 3, the organic EL display device 1 includes, between the base substrate 10 and the organic EL element 18, a base coating film 11, a plurality of TFTs 12, and an interlayer insulating film 13, which are arranged in the order stated, with the base coating film 11 being closest to the base substrate 10.

The base substrate 10 is a plastic substrate including a polyimide resin, for example. In the present embodiment, the illustrated example of the base substrate is a flexible and insulating transparent resin substrate, but the base substrate may be an insulating transparent glass substrate or an electrically conductive opaque metal sheet, for example.

As illustrated in FIG. 3, the base coating film 11 is disposed over the base substrate 10. The base coating film 11 is an inorganic film, such as a silicon oxide film or a silicon nitride film, for example.

As illustrated in FIG. 3, the TFT 12 is a switching element provided for each of the subpixels and disposed over the base coating film 11. The TFTs 12 each include, for example, a gate electrode, a gate insulator film, a semiconductor layer, and source and drain electrodes. The gate electrode is disposed over the base coating film 11. The gate insulator film is disposed to cover the gate electrode. The semiconductor layer is disposed over the gate insulator film and overlap the gate electrode. The source and drain electrodes are disposed over the semiconductor layer and face each other. In the present embodiment, the bottom-gate type is described as an example of the TFT 12, but the TFT 12 may be of the top-gate type.

As illustrated in FIG. 3, the interlayer insulating film 13 is disposed to cover the TFTs 12 except for a portion of each of the drain electrodes. The interlayer insulating film 13 includes, for example, a transparent organic resin material, such as an acrylic resin.

The organic EL element 18 is disposed over the display region D. As illustrated in FIG. 3, the organic EL element 18 includes first electrodes 14, edge covers 15, organic EL layers 16, and second electrodes 17, which are arranged in the order stated over the interlayer insulating film 13.

As illustrated in FIG. 3, the plurality of first electrodes 14 are arranged in a matrix form over the interlayer insulating film 13, and correspond to the respective subpixels. As illustrated in FIG. 3, the first electrodes 14 are connected to the respective drain electrodes of the TFTs 12 via respective contact holes formed in the interlayer insulating film 13. The first electrode 14 functions to inject holes into the organic EL layer 16. It is more preferable that the first electrodes 14 include a material having a large work function to improve the efficiency of hole injection into the organic EL layer 16. Examples of materials that may be included in the first electrode 14 include metal materials, such as silver (Ag), aluminum (Al), vanadium (V), cobalt (Co), nickel (Ni), tungsten (W), gold (Au), calcium (Ca), titanium (Ti), yttrium (Y), sodium (Na), ruthenium (Ru), manganese (Mn), indium (In), magnesium (Mg), lithium (Li), ytterbium (Yb), and lithium fluoride (LiF). Further examples of materials that constitute the first electrode 14 include alloys such as magnesium (Mg)-copper (Cu), magnesium (Mg)-silver

(Ag), sodium (Na)-potassium (K), astatine (At)-astatine oxide (AtO₂), lithium (Li)-aluminum (Al), lithium (Li)-calcium (Ca)-aluminum (Al), and lithium fluoride (LiF)-calcium (Ca)-aluminum (Al). Further examples of materials that may be included in the first electrode 14 include electrically conductive oxides, the examples of which include tin oxide (SnO), zinc oxide (ZnO), indium tin oxide (ITO), and indium zinc oxide (IZO). The first electrode 14 may include a stack of two or more layers of any of the above-mentioned materials. Examples of materials having a large work function include indium tin oxide (ITO) and indium zinc oxide (IZO).

As illustrated in FIG. 3, the edge cover 15 is disposed in a lattice pattern and surrounds the outer perimeter portion of the first electrodes 14. The edge cover 15 may be, for example, an inorganic film or an organic film. Examples of the inorganic film include silicon oxide (SiO₂), silicon nitride (SiN_x (x is a positive number)) such as trisilicon tetranitride (Si₃N₄), and silicon oxynitride (SiON). Examples of the organic film include polyimide resin, acrylic resin, polysiloxane resin, and novolac resin.

As illustrated in FIG. 3, the plurality of organic EL layers 16 are arranged in a matrix form on the respective first electrodes 14 and correspond to the respective subpixels. As illustrated in FIG. 4, the organic EL layers 16 each include a hole injecting layer 31, a hole transport layer 32, a light emitting layer 33, an electron transport layer 34, and an electron injecting layer 35, which are arranged in the order stated over the first electrode 14.

The hole injecting layer 31 is also referred to as an anode organic layer and has functions to reduce the energy level difference between the first electrode 14 and the organic EL layer 16 to improve the efficiency of hole injection into the organic EL layer 16 from the first electrode 14. Examples of materials that may be included in the hole injecting layer 31 include triazole derivatives, oxadiazole derivatives, imidazole derivatives, polyaryalkane derivatives, pyrazoline derivatives, phenylenediamine derivatives, oxazole derivatives, styrylanthracene derivatives, fluorenone derivatives, hydrazone derivatives, and stilbene derivatives.

The hole transport layer 32 functions to improve the efficiency of hole transport from the first electrode 14 to the organic EL layer 16. Examples of materials that may be included in the hole transport layer 32 include porphyrin derivatives, aromatic tertiary amine compounds, styrylamine derivatives, polyvinylcarbazole, poly-p-phenylenevinylene, polysilane, triazole derivatives, oxadiazole derivatives, imidazole derivatives, polyaryalkane derivatives, pyrazoline derivatives, pyrazolone derivatives, phenylenediamine derivatives, arylamine derivatives, amine-substituted chalcone derivatives, oxazole derivatives, styrylanthracene derivatives, fluorenone derivatives, hydrazone derivatives, stilbene derivatives, hydrogenated amorphous silicon, hydrogenated amorphous silicon carbide, zinc sulfide, and zinc selenide.

The light emitting layer 33 is a region where the holes and the electrons recombine, when a voltage is applied via the first electrode 14 and the second electrode 17, holes and electrons are injected from the first electrode 14 and the second electrode 17, respectively. The light emitting layer 33 includes a material having a high light emitting efficiency. Examples of materials that may be included in the light emitting layer 33 include metal oxinoid compounds (8-hydroxyquinoline metal complexes), naphthalene derivatives, anthracene derivatives, diphenyl ethylene derivatives, vinyl acetone derivatives, triphenylamine derivatives, butadiene derivatives, coumarin derivatives, benzoxazole

derivatives, oxadiazole derivatives, oxazole derivatives, benzimidazole derivatives, thiazole derivatives, benzothiazole derivatives, styryl derivatives, styrylamine derivatives, bisstyrylbenzene derivatives, tristyrylbenzene derivatives, perylene derivatives, perinone derivatives, aminopyrene derivatives, pyridine derivatives, rhodamine derivatives, aquidine derivatives, phenoxazine, quinacridone derivatives, rubrene, poly-p-phenylenevinylene, and polysilane.

The electron transport layer **34** functions to facilitate migration of the electrons to the light emitting layer **33** efficiently. Examples of materials that may be included in the electron transport layer **34** include organic compounds, the examples of which include oxadiazole derivatives, triazole derivatives, benzoquinone derivatives, naphthoquinone derivatives, anthraquinone derivatives, tetracyanoanthraquinodimethane derivatives, diphenoquinone derivatives, fluorenone derivatives, silole derivatives, and metal oxinoid compounds.

The electron injecting layer **35** functions to reduce the energy level difference between the second electrode **17** and the organic EL layer **16**, to improve the efficiency of electron injection into the organic EL layer **16** from the second electrode **17**. By this function, the driving voltage for the organic EL element **18** can be reduced. Note that the electron injection layer **35** is also referred to as a cathode organic layer. Examples of materials that constitute the electron injection layer **35** include inorganic alkaline compounds such as lithium fluoride (LiF), magnesium fluoride (MgF₂), calcium fluoride (CaF₂), strontium fluoride (SrF₂), and barium fluoride (BaF₂); aluminum oxide (Al₂O₃), and strontium oxide (SrO).

As illustrated in FIG. 3, the second electrode **17** is disposed to cover the organic EL layers **16** and the edge covers **15**. The second electrode **17** functions to inject electrons into the organic EL layer **16**. It is more preferable that the second electrode **17** includes a material having a small work function to improve the efficiency of electron injection into the organic EL layer **16**.

Examples of materials that may be included in the second electrode **17** include silver (Ag), aluminum (Al), vanadium (V), cobalt (Co), nickel (Ni), tungsten (W), gold (Au), calcium (Ca), titanium (Ti), yttrium (Y), sodium (Na), ruthenium (Ru), manganese (Mn), indium (In), magnesium (Mg), lithium (Li), ytterbium (Yb), and lithium fluoride (LiF). Further the second electrode **17** may be formed of alloys such as (Mg)-copper (Cu), magnesium (Mg)-silver (Ag), sodium (Na)-potassium (K), astatine (At)-astatine oxide (AtO₂), lithium (Li)-aluminum (Al), lithium (Li)-calcium (Ca)-aluminum (Al), and lithium fluoride (LiF)-calcium (Ca)-aluminum (Al), for example. Further examples of materials that may be included in the second electrode **17** include electrically conductive oxides, the examples of which include tin oxide (SnO), zinc oxide (ZnO), indium tin oxide (ITO), and indium zinc oxide (IZO). The second electrode **17** may include a stack of two or more layers of any of the above-mentioned materials. Examples of materials having a small work function include magnesium (Mg), lithium (Li), lithium fluoride (LiF), magnesium (Mg)-copper (Cu), magnesium (Mg)-silver (Ag), sodium (Na)-potassium (K), lithium (Li)-aluminum (Al), lithium (Li)-calcium (Ca)-aluminum (Al), and lithium fluoride (LiF)-calcium (Ca)-aluminum (Al).

The sealing film **25** is disposed over the display region D and the non-display region N, and covers the organic EL element **18**. The sealing film **25** functions to protect the organic EL element **18** from moisture and oxygen. As

illustrated in FIG. 2, the sealing film **25** includes a first inorganic layer **19**, an organic layer **20**, and a second inorganic layer **21**, which are arranged in this order from the organic EL element **18** side.

More specifically, the sealing film **25** is disposed on the surface of the organic EL element **18**, and includes the first inorganic layer **19**, the organic layer **20**, and the second inorganic layer **21**. The first inorganic layer **19** includes a first inorganic film. The organic layer **20** includes an organic film and is disposed on the surface of the first inorganic layer **19**. The second inorganic layer **21** includes a second inorganic film and is disposed on the surface of the organic layer **20**.

As illustrated in FIG. 2, the first inorganic layer **19** includes a silicon oxide (SiO_x) layer **19a** and a silicon nitride (SiN_x) layer **19b**. The silicon oxide layer **19a** is disposed on the surface of the organic EL element **18**. The silicon nitride layer **19b** is disposed on the surface of the silicon oxide layer **19a** and is in contact with the organic layer **20**.

As illustrated in FIG. 2, the second inorganic layer **21** includes a silicon oxide layer **21a** and a silicon nitride layer **21b**. The silicon oxide layer **21a** is disposed on the surface of the organic layer **20**. The silicon nitride layer **21b** is disposed on the surface of the silicon oxide layer **21a**.

The organic layer **20** is formed of an organic film such as acrylate, polyurea, parylene, polyimide, or polyamide. As illustrated in FIG. 2, the organic layer **20** is covered by the second inorganic layer **21**.

The organic EL display device **1**, configured as described above, is flexible. In each of the subpixels, the light emitting layer **33** of the organic EL layer **16** is configured to emit light via the TFT **12** appropriately so that images can be displayed.

Next, a method for manufacturing the organic EL display device according to the present embodiment will be described. FIGS. 5 to 8 are cross-sectional views illustrating a method for manufacturing the organic EL display device according to the present embodiment.

The organic EL display device **1** according to the present embodiment can be produced in the following manner, for example. First, as illustrated in FIG. 3, the base coating film **11** is formed on the surface of the base substrate **10**, which includes a polyimide resin. Thereafter, the plurality of TFTs **12** for driving the organic EL element **18** are formed on the base coating film **11** at a predetermined interval. Next, a photosensitive acrylic resin is applied to the base coating film **11**, on which the TFTs **12** are disposed, by spin coating. The applied photosensitive acrylic resin is exposed to a predetermined amount of light through a photomask having a predetermined exposure pattern and then is subjected to development with an alkaline developer. In this manner, the interlayer insulating film **13** is formed over the base coating film **11** to cover the TFTs **12**, as illustrated in FIG. 3. In the process, contact holes (e.g., 5 μm in diameter) for electrically connecting the first electrodes **14** to the TFTs **12** are formed in the interlayer insulating film **13**.

Next, as illustrated in FIG. 3, the organic EL element **18** (first electrodes **14**, edge covers **15**, organic EL layers **16** (hole injecting layers **31**, hole transport layers **32**, light emitting layers **33**, electron transport layers **34**, electron injecting layers **35**), second electrode **17**) are formed on the surface of the interlayer insulating film **13** by using a known method.

Next, the first inorganic layer **19** is formed to cover the organic EL element **18**. More specifically, first, silicon oxide is stacked over the surfaces of the base substrate **10** and the

organic EL element **18** by using, for example, a plasma CVD method with a mask, a sputtering method, or an atomic layer deposition method (ALD method). Thus, the silicon oxide layer **19a** is formed to cover the surface of the organic EL element **18**, as illustrated in FIG. 5.

Next, as with the silicon oxide layer **19a** described above, silicon nitride is stacked on the surface of the silicon oxide layer **19a** by using, for example, a plasma CVD method with a mask, a sputtering method, or an atomic layer deposition method (ALD method). Thus, the silicon nitride layer **19b** is formed on the base substrate by use of a mask having a larger opening than the display region D to cover the surface of the organic EL element **18**, as illustrated in FIG. 6. In this manner, the first inorganic layer **19**, which includes the silicon oxide layer **19a** and the silicon nitride layer **19b**, is formed.

Next, as illustrated in FIG. 7, a partition **30** is provided on the first inorganic layer **19** such that the partition **30** is disposed inward from the edges of the first inorganic film **19**. The partition **30** defines a coating region of an organic material for forming the organic layer **20** (i.e., a formation region of the organic layer **20**).

Moreover, in a case of using a metal mask for the partition **30**, a magnet member (not illustrated) having a magnetic force is provided on a surface of the base substrate **10**, opposite to the side on which the partition **30** is provided, so that the magnetic force of the magnet member allows the partition **30** to be secured on the first inorganic layer **19**.

Next, an organic material is stacked on the surface **26** of the silicon nitride layer **19b** and inside the partition **30** (i.e., a formation region of the organic layer **20** illustrated in FIG. 2) by using, for example, an ink-jet method or a vacuum vapor deposition method. Examples of the organic material include acrylate, polyurea, parylene, polyimide, and polyamide. Thus, the organic layer **20** formed of the organic film is formed on the surface **26** of the silicon nitride layer **19b**, as illustrated in FIG. 8.

Here, the partition **30** thus provided on the first inorganic layer **19** restricts spreading of an organic material applied at the time of forming the organic layer **20**.

Further, as illustrated in FIG. 8, a recessed portion **30a** is formed on a side of the partition **30**, the side facing the organic layer **20**. At this time, the organic material that constitutes the organic layer **20** does not spread to the inner part of the recessed portion **30a** and remains around the partition **30** by surface tension of the organic material. Thus, the recessed portion **30a** enables a water-repellent function to be provided. As a result, the recessed portion **30a** can certainly restrict the spreading of the organic material at the time of forming the organic layer **20**.

Specifically, as illustrated in FIG. 8, a cavity in which the organic layer **20** is not formed is provided inside the recessed portion **30a** on the first inorganic layer **19** in a process for forming the organic layer **20** described below. As illustrated in FIG. 1, the organic layer **20** is formed inside the first inorganic layer **19** in a plan view.

Next, after the organic layer **20** is cured, the partition **30** is removed from the surface of the first inorganic layer **19**. For example, in a case of using the metal mask for the partition **30**, the organic material is cured by heating, and then the base substrate **10** and the partition **30** are cooled so that the partition **30** can be separated and removed from the surface of the first inorganic layer **19**.

Next, the second inorganic layer **21** is formed on the first inorganic layer **19** to cover the organic layer **20**. More specifically, first, silicon oxide is stacked over the surface of the organic layer **20** by using, for example, a plasma CVD

method with a mask, a sputtering method, or an atomic layer deposition method (ALD method). Thus, the silicon oxide layer **21a** is formed to cover the surface of the organic layer **20**, as illustrated in FIG. 2.

Next, as with the silicon oxide layer **21a** described above, silicon nitride is stacked on the surface of the silicon oxide layer **21a** by using, for example, a plasma CVD method with a mask, a sputtering method, or an atomic layer deposition method (ALD method). Thus, the silicon nitride layer **21b** is formed to cover the surface of the organic layer **20**, as illustrated in FIG. 2. In this manner, the second inorganic layer **21**, which includes the silicon oxide layer **21a** and the silicon nitride layer **21b**, is formed; and the sealing film **25**, which includes the first inorganic layer **19**, the organic layer **20**, and the second inorganic layer **21**, is formed.

The organic EL display device **1** of the present embodiment can be manufactured as described above.

The method for manufacturing the organic EL display device **1** of the present embodiment described above produces the following effects (1) and (2).

(1) After the partition **30** is formed on the first inorganic layer **19**, an organic material is applied inward from the partition **30** on the surface of the first inorganic layer **19** to form the organic layer **20** on the first inorganic layer **19**. After that, the partition **30** is removed. Accordingly, since the known dam wall is not necessary, the frame region N does not need to include the dam wall. As a result, the frame narrowing of the organic EL display device **1** can be performed.

(2) The partition **30** has the recessed portion **30a** on a side facing the organic layer **20**. The recessed portion **30a** causes a water-repellent function to be provided, and thus the spreading of the organic material is certainly restricted at the time of forming the organic layer **20**.

Second Embodiment

A second embodiment of the disclosure will be described below. FIGS. 9 and 10 are cross-sectional views, each illustrating a method for manufacturing the organic EL display device according to the present embodiment. Note that the entire configuration of the organic EL display device is the same as that of the first embodiment described above, and detailed descriptions thereof will be omitted. Note that elements common to those in the first embodiment are denoted by the same reference signs, and duplicated descriptions thereof will be omitted.

In a case of manufacturing the organic EL display device **1** according to the embodiment, a mask **45** having a larger opening than the display region D is fixed onto the base substrate. Note that the mask **45** defines a coating region of an organic material for forming the organic layer **20** (i.e., a formation region of the organic layer **20**).

Further, as illustrated in FIG. 9, as with the recessed portion **30a** of the partition **30**, a recessed portion **45a** is formed on a side of the mask **45**, the side facing the organic layer **20**. The recessed portion **45a** has the same function as the recessed portion **30a** of the partition **30**.

In addition, a metal mask is used for the mask **45**. As with the partition **30** according to the first embodiment, a magnet member (not illustrated) having magnetic force is provided on a surface of the base substrate **10** opposite to the surface having the mask **45**. Thus, the magnetic force of the magnet member retains the mask **45** on the base substrate **10**.

More specifically, first, silicon oxide is stacked on the surfaces of the base substrate **10** and the organic EL element **18** by using, for example, a plasma CVD method, a sput-

tering method, or an atomic layer deposition method (ALD method) using the mask **45**. Thus, the silicon oxide layer **19a** is formed to cover the surface of the organic EL element **18**, as illustrated in FIG. **9**.

Next, as with the silicon oxide layer **19a** described above, silicon nitride is stacked on the surface of the silicon oxide layer **19a** by using, for example, a plasma CVD method, a sputtering method, or an atomic layer deposition method (ALD method) using the mask **45**. Thus, the silicon nitride layer **19b** is formed to cover the surface of the organic EL element **18**, as illustrated in FIG. **9**. In this manner, the first inorganic layer **19**, which includes the silicon oxide layer **19a** and the silicon nitride layer **19b**, is formed.

Next, an organic material is applied inward from the edges of the first inorganic layer **19** (i.e., a formation region of the organic layer **20** illustrated in FIG. **2**) on the surface **26** of the silicon nitride layer **19b** by using, for example, an ink-jet method or a vacuum vapor deposition method.

Examples of the organic material include acrylate, polyurea, parylene, polyimide, and polyamide. Thus, the organic layer **20** formed of the organic film is formed on the surface **26** of the silicon nitride layer **19b**, as illustrated in FIG. **10**.

Here, as with the partition **30** of the first embodiment, a cavity in which the organic layer **20** is not formed is provided inside the recessed portion **45a** on the first inorganic layer **19** in a process for forming the organic layer **20** as illustrated in FIG. **10**. Thus, the organic layer **20** is formed inside the first inorganic layer **19** in a plan view as illustrated in FIG. **1**.

Note that after the organic material is applied, the organic layer **20** is provisionally cured by UV irradiation, with the mask **45** that functions as a partition being provided. After that, the organic layer **20** is baked at approximately 70 to 100° C. and thus completely cured. Alternatively, preheating, which is executed at the time of forming the second inorganic layer **21** by using a CVD method described below, can replace such baking.

Next, after the organic layer **20** is cured, the mask **45** is removed from the surface of the base substrate **10**.

Next, as with the first embodiment, the second inorganic layer **21** including the silicon oxide layer **21a** and the silicon nitride layer **21b** is formed on the first inorganic layer **19** to cover the organic layer **20**, thus forming the sealing film **25** including the first inorganic layer **19**, the organic layer **20**, and the second inorganic layer **21**.

The organic EL display device **1** according to the present embodiment can be manufactured as described above.

The manufacturing method for the organic EL display device **1** according to the present embodiment described above produces the following effect (3) in addition to the effects (1) and (2) described above.

(3) The mask **45** used for forming the first inorganic layer **19** is also used as a partition at the time of forming the organic layer **20**. This simplifies the process for manufacturing the organic layer **20** and saves costs.

Note that the embodiments described above can be modified as follows.

As illustrated in FIG. **11**, a Teflon coating layer **40** can be formed on the surface of the partition **30** of the embodiments described above. Such configuration imparts water-repellent property not only to the recessed portion **30a** described above but also to the entire surface of the partition **30**. This can suppress variation in a formation region of the organic layer **20** at the time of forming the organic layer **20**. Moreover, this can prevent an inconvenience in which an organic material for forming the organic layer **20** adheres to the surface of the partition **30** and cures.

In the embodiments described above, the metal mask made of, for example, SUS is used for the partition **30**. However, the partition **30** can be also formed by patterning a photosensitive organic resin material by use of a gray tone mask or a half-tone mask.

Moreover, the mask used for forming the second inorganic layer **21** can be also disposed outward from the partition **30** or the mask **45** (outward in the width direction Y of the organic EL display device **1** illustrated in FIG. **12**) of the embodiments described above so that the second inorganic layer **21** can be provided to cover a peripheral edge of the first inorganic layer **19** as illustrated in FIG. **12**.

In the embodiments described above, the example of the organic EL layer is given that has the five-layer structure including the hole injection layer, the hole transport layer, the light emitting layer, the electron transport layer, and the electron injection layer. The organic EL layer may have, for example, a three-layer structure including a hole injection-transport layer, a light emitting layer, and an electron transport-injection layer.

In the embodiments described above, the example of the organic EL display device is given that includes the first electrode as an anode and the second electrode as a cathode. However, the disclosure is also applicable to an organic EL display device, in which the layered structure of the organic EL layer is reversed, with the first electrode being a cathode and the second electrode being an anode.

In the embodiments described above, the example of the organic EL display device is given that includes the element substrate in which the electrode of the TFT connected to the first electrode is the drain electrode. However, the disclosure is also applicable to an organic EL display device including an element substrate in which the electrode of the TFT connected to the first electrode is referred to as the source electrode.

In the embodiments described above, organic EL display devices are described as display devices by way of example. The disclosure is also applicable to display devices including a plurality of electro-optical elements that are driven by an electrical current. For example, the disclosure is applicable to display devices including quantum dot light emitting diodes (QLEDs), which are light emitting elements using a quantum dot-containing layer.

INDUSTRIAL APPLICABILITY

As described above, the disclosure is useful for manufacturing methods for organic EL display devices.

REFERENCE SIGNS LIST

- 1** Organic EL display device
- 10** Base substrate
- 11** Base coating film
- 12** TFT
- 13** Interlayer insulating film
- 16** Organic EL layer
- 18** Organic EL element
- 19** First inorganic layer
- 20** Organic layer
- 21** Second inorganic layer
- 25** Sealing film
- 30** Partition
- 30A** Recessed portion
- 40** Teflon coating layer
- 45** Mask

11

The invention claimed is:

1. A method for manufacturing a display device, the method comprising:
forming a light emitting element on a base substrate; and
forming a sealing film to cover the light emitting element, wherein the forming a sealing film includes
fixing a mask including a larger opening than a display region on the base substrate,
forming a first inorganic layer inside the mask to cover the light emitting element,
forming an organic layer on the first inorganic layer by applying an organic material inside the first inorganic layer on a surface of the first inorganic layer by use of the mask,
removing the mask from the base substrate,
forming a second inorganic layer on the first inorganic layer to cover the organic layer, and
during the forming an organic layer, the organic layer is cured by UV irradiation with the mask being provided on the base substrate.

12

2. The method for manufacturing a display device according to claim 1,
wherein the mask includes a recessed portion on a side facing the organic layer.
3. The method for manufacturing a display device according to claim 2,
wherein during the forming an organic layer, a cavity in which the organic layer is not formed is provided inside the recessed portion on the first inorganic layer to form the organic layer inside the first inorganic layer in a plan view.
4. The method for manufacturing a display device according to claim 1,
wherein the light emitting element is an organic EL element.
5. The method for manufacturing a display device according to claim 1,
wherein the base substrate is flexible.

* * * * *

专利名称(译)	密封膜有机层的紫外线固化制造显示装置的方法		
公开(公告)号	US10497907	公开(公告)日	2019-12-03
申请号	US16/466682	申请日	2017-09-26
[标]申请(专利权)人(译)	夏普株式会社		
申请(专利权)人(译)	夏普株式会社		
当前申请(专利权)人(译)	夏普株式会社		
[标]发明人	MATSUI AKIHIRO TAKAHASHI JUMPEI SENOO TOHRU HIRASE TAKESHI SONODA TOHRU OCHI TAKASHI OCHI HISAO		
发明人	MATSUI, AKIHIRO TAKAHASHI, JUMPEI SENOO, TOHRU HIRASE, TAKESHI SONODA, TOHRU OCHI, TAKASHI OCHI, HISAO		
IPC分类号	H01L51/56 H01L51/52 H01L27/32 H01L51/00 B05D1/00		
CPC分类号	H01L51/0097 H01L51/5253 H01L51/5256 H01L51/56 H01L27/3244 B05D1/60 H01L2251/5338 G09F9/30 H05B33/02 H05B33/04 H05B33/10		
审查员(译)	JUNG , MICHAEL		
其他公开文献	US20190363293A1		
外部链接	Espacenet		

摘要(译)

提供一种用于制造有机EL显示装置的方法，该方法包括形成密封膜以覆盖有机EL元件。形成密封膜的步骤包括：形成第一无机层以覆盖有机EL元件；在第一无机层上形成隔板；通过从隔板的表面向内施加有机材料，在第一无机层上形成有机层。第一无机层，去除隔板，并在第一无机层上形成第二无机层以覆盖有机层。

